

SimpleIO™
Get to the Point.™

Mailing Address:
5663 Balboa Ave. #377
San Diego, CA 92111

P: 858-268-2841
F: 661-885-9549
support@quicksource.com

www.SimpleIO.com

TriacOut8

1799-002-xx

This 8-channel triac output board has everything you need for just about any AC output interfacing. The board features an optoisolated triac per channel, providing an 8-point solid-state-relay circuit for AC control. It has plug-in and terminal block connectors, a fuse with snap-in cover/holder for easy replacement, and optoisolators and triacs to drive each output point. The TriacOut8 series of boards has additional connector and input drive options compared to the TriacOut4 and 12. Providing flexibility at the risk of being less "simple," the board interfaces to controllers in a variety of ways.

Package Contents:

- Description and Specifications
- Schematic
- Assembly Drawing
- Bill of Material
- Warning Statement

Thank you for your interest in our SimpleIO products, and we hope your project is successful. If you have any questions, comments, or suggestions, we're happy to help. We would appreciate any reviews or comments you wish to email or post on your favorite forums. Let us know what you think!

WARNING!

KNOW WHAT YOU ARE DOING!

SELECT AND USE QUICKSOURCE INC'S SIMPLEIO PRODUCTS AND MATERIALS AT YOUR OWN RISK.

PLEASE READ THE FULL WARNING ON THE LAST PAGE OF THIS DOCUMENT.

Copyright 2004-2006 QuickSource, Inc.

Unless otherwise specified, all materials containing logos, graphics, icons and images of QuickSource and SimpleIO, as well as the selection, assembly, and arrangement, are the sole property of QuickSource, Inc.

No materials may be copied, reproduced, modified, republished, uploaded, posted, transmitted, or distributed in any form or by any means without prior written permission.

All rights are reserved.

TriacOut8 Description

The triac output board has inputs common to all channels, and an output circuit for each channel. The individual channels are a circuit made up of a logic input connector, optoisolator, triac, and AC output connector.

The logic input has connectors with a pins for a common 5 VDC supply or ground, and a pin for each channel. There are two connectors in parallel, a terminal block and right-angle header, for flexibility with wiring or board-to-board connections. There is also an RJ45 connector option for the logic inputs, to use Cat5 network cable for the control. This connector has jumper options for the use of one of its eight pins.

The logic input has an assembly option for sinking or sourcing the current through the optos. For sinking, supply +5V to the board, and sink each input to ground. For sourcing, connect ground to the board, and source each input with +5V. When assembling, the pullup resistors are installed in one location for sinking, and another location for sourcing. See the assembly drawing for details.

The inputs connect to a zero-crossing optoisolator for each channel, with triac driver outputs. The optoisolators and their resistors operate up to 120 VAC, with an assembly option for 24 VAC. The optoisolators drive the triacs, switching the AC input to the output connectors. The triacs are lined up on one side of the board, to make it easy to connect to a heat sink. They have isolated tabs to avoid making the heat sink live. Each triac is spec'ed for 8A, but typically limit each channel to 1A at 120 VAC.

The AC input is a 2-pin plug-in connector, and a fuse with a snap-in cover/holder for easy replacement. The AC output connectors are 2-pin plug-in connectors, one for each channel, with pins for the switched and common (hot and neutral) for wiring convenience.

The AC wiring connectors are plug-in screw connectors, for convenience. This is a new feature in this latest revision of the TriacOut8 board. The connectors are located along the center of the board behind the triacs, so the plugs help you bring the wiring away from the board cleanly. For your flexibility, we also have a no-connector version of the board without the plug-in connectors and terminal blocks, for assembling with your specific style of connectors.

The board does not have the locations for snubber components if driving inductive loads, like the other TriacOut boards, due to space for the plug-in connectors. Wire the snubber components into the plug with the AC wiring.

Specifications

- 8 opto-isolated Triac AC output points.
- Triacs: 8A max, typically for 1A, 120 VAC on each point.
- Optoisolators: zero-crossing, triac-driver, 120 VAC or 24 VAC typical, input +5 VDC at low-current 5 mA.
- Logic input sink/source assembly option:
 - Sinking: Supply +5 VDC, ground each point to enable.
 - Sourcing: Connect common ground, source +5 VDC on each point to enable.
- Connectors:
 - Logic input right-angle header on 0.1" centers.
 - Logic input terminal block on 0.1" centers.
 - Logic input RJ45 connector option, with jumper options for the use of pin 1.
 - AC input and output plug-in connectors on 0.2" centers.
 - AC outputs have hot and neutral pins for each channel.
- Fuse: 10A common to all outputs, 5x20mm in a snap-in holder.
- PC Board: 2-sided, 0.062", with solder-mask and silkscreen.
- 6.75" long x 2" wide. Height of triacs are less than 1".

TriacOut8 Part Number Selector

This is a selection guide for the various TriacOut8 part numbers.

Each -xx part number suffix selects a combination of the operating voltage, terminal blocks, the RJ45 connector, and the sinking or sourcing input option.

TriacOut8 Part Number	VAC		Connectors		Input control	
	120 VAC	24 VAC	Term Block / Plug-in	RJ45	Sink	Source
Kits 1777-002-xx	-01	-09	●		●	
	-02	-10			●	
	-03	-11	●	●	●	
	-04	-12		●	●	
Assembled 1799-002-xx	-05	-13	●			●
	-06	-14				●
	-07	-15	●	●		●
	-08	-16		●		●

- **VAC** Part numbers -01 through -08 operate at 120 VAC. Part numbers -09 through -16 operate at lower voltages, typically 24 VAC. The difference is the rating of the optoisolator and the value of the gate resistor.
- **Term Block / Plug-in** Include the logic terminal block connector, and AC plug-in connectors. This is an option to provide a balance between convenience and cost. The connectors are very useful for field wiring. Or, leave these connectors off to save cost and solder your own connectors.
- **RJ45** Include the logic input RJ45 connector. This option provides a way to conveniently use Cat5 network cable for the logic inputs, for some controller configurations. Leave this option off to avoid the slight cost increase if using the header or terminal block connectors.

There is a jumper for the use of pin 1 of the connector. Since the RJ45 has only 8 pins, the choice for pin 1 is to provide the power or ground, and only control channels 2-8; or to control all 8 channels, but require power or ground on a separate connector.

Include a comment for the RJ45 Pin 1 jumper choice when ordering boards with the RJ45 connector, as one of the following:

 - +5V +5V supply for the sinking input configuration. Control channels 2-8.
 - Gnd Ground return connection for the sourcing input configuration. Control channels 2-8.
 - In1 Logic input 1. This controls all 8 channels from the RJ45 connector, but requires power or ground elsewhere.
- **Sink** This installs the opto pullup resistors for logic input sinking.
Supply +5 VDC to the board, and sink each input to ground to turn on each output.
- **Source** This installs the opto pullup resistors for logic input sourcing.
Connect a ground return to the board, and source each input with +5 VDC to turn on each output.

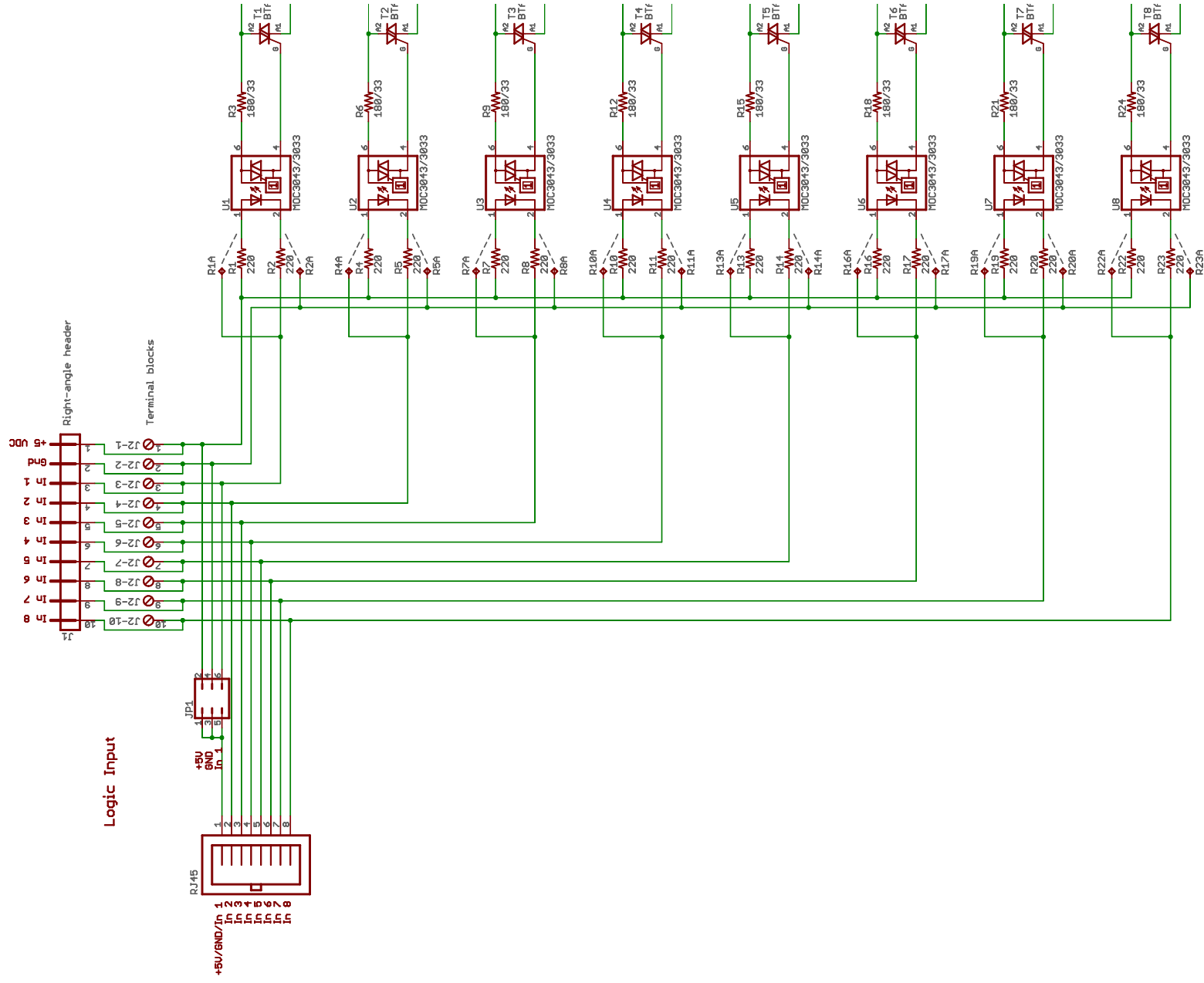

Notes:

Populate opto and gate resistor for VAC as appropriate. See assembly drawing.
 Configure board for sinking or sourcing opto input current.

To sink, install resistors as shown, and supply +5V. Gnd is unused. Logic inputs sink to ground.
 To source, install resistors in dotted lines, and supply Gnd. +5V is unused. Logic inputs source +5V.
 The RJ45 Cat5 connector has jumper options for pin 1.

Use pin 1 to supply +5V, GND, or for Input 1 signal.

WARNING!
 KNOW WHAT YOU ARE DOING!
 SELECT AND USE QUICKSOURCE INC'S
 SIMPLIPIO PRODUCTS AT YOUR OWN RISK.
 READ THE FULL WARNING ON THE LAST PAGE.

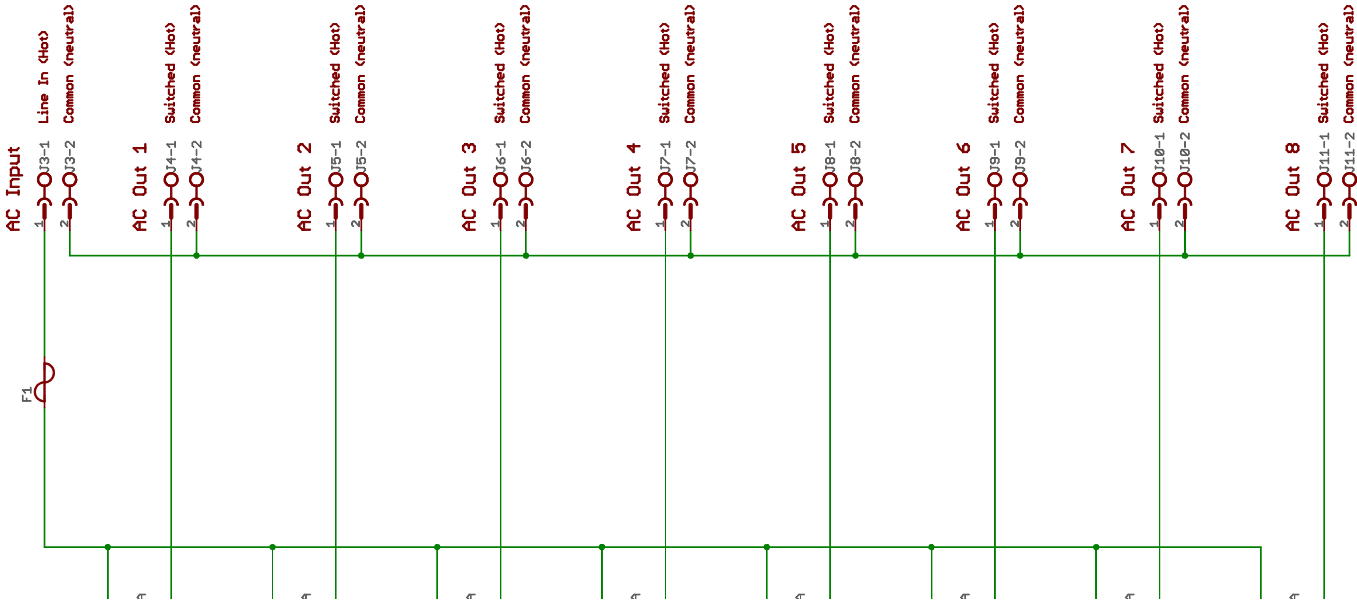

simpleIO.com

s and specifications are
of QuickSource, Inc.
use drawings may be reproduced
in any form or by any means
written permission
?, Inc.

QuickSource, Inc.
mailing address: Phone: 858-268-2841
5663 Balboa Ave. #377 Fax: 661-885-9549
San Diego, CA 92111
support@quicksource.com
Copyright 2006 QuickSource, Inc.

Assy	Date	Description
C	01/22/2006	Board rev B. Header/Plug AC connectors. Remove MOV footprints for space.
B	09/15/2005	Note opto and gate resistor options. No board change.
A	02/08/2005	Initial version from TriacOut4 B Dual pullups. Sink/Source. Change opto to MOC3043 Change series gate resistors to 180 ohms. Add RJ45 connector and jumpers.
		SimpleI/O - TriacOut8
		TITLE: TriacOut8
		Document Number: Assy 1799-002-xx Board 1700-002
		REV: C B
		Date: 01/22/2006 Sheet: 1/1

Notes:

1. Assy part number 1799-002-xx. See order and BOM for specific -xx assembly.
2. Not all parts are populated. See specific -xx BOM for parts list.
3. Leave the assembly -xx number and revision letter boxes blank until shipping.
4. J2 is made up of two connectors: 6-pin and 4-pin, for availability and common inventory
5. Sink / Source

This board has an assembly option for driving the logic inputs by either sinking or sourcing. For sinking (part numbers -01 to -04 and -09 to -12), supply +5V to the board, and sink where the 16 220 ohm resistors (R1, etc) in the left and center pads, where the silkscreen shows the resistor outline. Leave the right pad (R1A, etc) unconnected. For sourcing (part numbers -05 to -08 and -13 to -16), connect Gnd to the board, and sink where the 16 220 ohm resistors (R1A, etc) in the center and right pads. Leave the left pad unconnected.

See enlargement to the right.

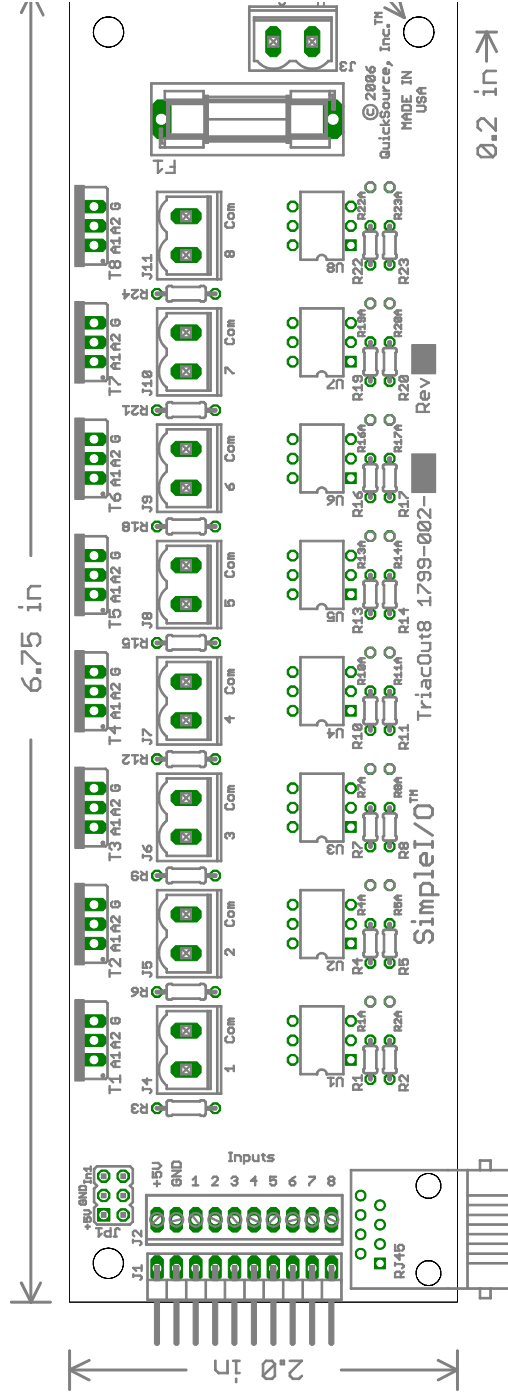

0.2 in →

6. JP1

Jumper JP1 determines the use of pin 1 of the RJ45 connector. Specify jumper location with

- Pins 1-2 (left): +5V +5V supply for sinking configuration
- Pins 3-4 (center): Gnd Ground return for sourcing configuration
- Pins 5-6 (right): In1 Logic input 1

Note: JP1 holes take 0.025" square posts, but soldered wire jumper is better.

7. There are only three mounting holes.

Use RJ45 hole if not using connector. Use rubber bumper if needed.

8. Connector selection (Part Number table)

- "Connectors" refers to J2 - J11: Logic input, AC input, AC output connectors.
- "RJ45" connector is listed as a separate option.
- J1 Logic input right-angle header is always included.

WARNING!
 KNOW WHAT YOU ARE DOING!
 READ THE FULL WARNING
 ON THE LAST PAGE.

parts.

ancing the current through the optos.
 k each input to ground.

Note 5: Sink / Source (changed from Rev A boards)

ected.

source each input with +5V.

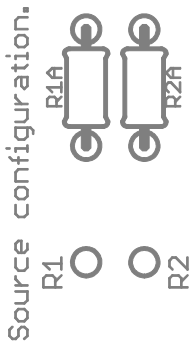
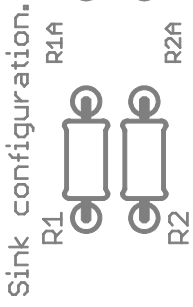

Install the 16 resistors
 as shown on silkscreen,
 in the left and center pads.
 Leave the right pad empty.

Install the 16 resistors
 as shown here, in 'A' position,
 in the center and right pads.
 Leave the left pad empty.

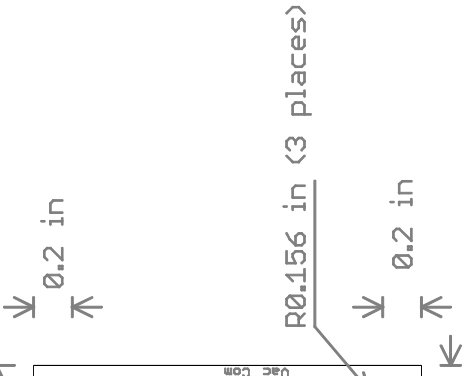

Assy Board

C	B	01/22/2006
B	A	09/15/2005
A	A	02/09/2005

then ordering.

TriacOut8 Part Number Selector 1799-002-xx			
120-240 VAC	24 VAC	Connectors (see note 8)	RJ45 Sink Source
-01	-09	●	●
-02	-10		●
-03	-11	●	●
-04	-12		●
-05	-13	●	●
-06	-14		●
-07	-15	●	●
-08	-16		●

Board Rev B.

Header/Plug AC connectors. Change AC layout.
 Change sink/source layout. Remove MOVs.

Note 24 VAC options
 No board change.

Initial version from TriacOut4 B
 Dual pullups. Sink/Source.
 Add RJ45 connector and jumpers.

QuickSource, Inc.

mailing address: Phone: 858-268-2841
 5663 Balboa Ave. #377 Fax: 661-885-9549
 San Diego, CA 92111
 support@quicksource.com

SimpleI/O - TriacOut8-xx

TITLE: TriacOut8-xx

Document Number:

Assy 1799-002-xx

ASSY REV:

C

Copyright 2006 QuickSource, Inc.

Date: 01/22/2006

Simple I/O

QuickSource, Inc.
5663 Balboa Ave. #377
San Diego, CA 92111

P: 858-268-2841
F: 661-885-9549

Bill of Material

support@quicksourc.com

Product Name	Part No.	Version	Description		2/22/2006
TriacOut8 (24 VAC, sink)	1799-002-09	C	TriacOut8, sink drive, 24 VAC	Similar to -01, but populated for 24 V	
TriacOut8 (24 VAC, source)	1799-002-13	C	TriacOut8, source drive, 24 VAC	Similar to -05, but populated for 24 V	
Description	Part No.	Mfr	Mfr No.	Qty Each	Ref Des
PCB, TriacOut8	1700-002 rev B	QuickSource		1	
Conn, Header, 0.100, 10-pin, Rt Angle	2100-003	Samtec	TSW-110-08-T-S-RA	1	J1
Conn, Header, Pluggable, 0.200, 2-pin	2100-007	Molex	39860-0502	9	J3-J11
Conn, Recp, Pluggable, 0.200, 2-pin, Rt Angle, Top 180 entry	2100-008	Molex	39860-0102	9	J3-J11
Kit, Conn, Term Block, MPT, 0.100, 10-pin	2157-005			1	J2
Conn, Term Block, MPT, 0.100, 6-pin	2150-001	Phoenix Contact	1725698		Connector made up of two individual connectors
Conn, Term Block, MPT, 0.100, 4-pin	2150-004	Phoenix Contact	1725672		
IC, Opto, triac, zero-crossing, 5mA, 250V	3130-004	Fairchild	MOC3033M	8	U1-U8
Fuseholder, 5x20, PC mount	4300-001	Keystone	4527	1	F1
Fuseholder, 5x20, cover	4300-002	Keystone	4527C	1	F1
Fuse, 5x20, 125V, 10A	4300-004	Bussman	GMA-10	1	F1
Resistor, 220, 5%, mini	4700-003	Panasonic	ERDS2TJ221V	16	R1, 2, 4, 5, 7, 8, 10, 11, 13, 14, 16, 17, 19, 20, 22, 23 (see Sink/Source below)
Resistor, 33, 5%, mini	4700-005	Panasonic	ERDS2TJ330V	8	R3, 6, 9, 12, 15, 18, 21, 24
Triac, 8A, 400V, insulated	4800-002	STMicroelectronics	BTA08-400B	8	T1-T8
Unpopulated					
Conn, Recp, RJ45, 8-pin, Side entry	2100-005	Amp	520251-4	1	RJ45
Jumper pads, 2x3, 6-pin					JP1

Sink/Source:

The TriacOut8 board has an assembly option for driving the logic inputs by either sinking or sourcing the current through the optos.

Part number -09, for sinking, installs the 220 ohm resistors in one location.

Part number -13, for sourcing, installs the 220 ohm resistors in another location.

See assembly notes for details.

24 VAC:

The optoisolator is MOC3033M, rated for 250V, for 24VAC to 120VAC operation; or MOC3043M, rated for 400V.

The gate resistor is 33 ohms, for 24VAC operation.

NOTE:

This is a reference Bill of Material for a TriacOut board.

These parts are just suggestions for how the assembled boards may be produced.

Please use this as a reference, but evaluate parts and assemble the boards as you see fit, and at your own risk.

WARNING:

KNOW WHAT YOU ARE DOING!

SELECT AND USE QUICKSOURCE INC'S SIMPLEIO PRODUCTS AND MATERIALS AT YOUR OWN RISK.

PLEASE READ THE FULL WARNING ON THE LAST PAGE OF THIS DOCUMENT.

Copyright 2006 QuickSource, Inc.

Unless otherwise specified, all materials containing logos, graphics, icons and images of QuickSource and SimpleIO, as well as the selection, assembly, and arrangement, are the sole property of QuickSource, Inc.

No materials may be copied, reproduced, modified, republished, uploaded, posted, transmitted, or distributed in any form or by any means without prior written permission.

All rights are reserved.

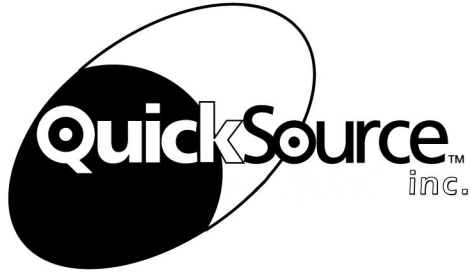

SimpleIO™
Get to the Point.™

WARNING!

**KNOW WHAT YOU ARE DOING!
SELECT AND USE QUICKSOURCE INC'S SIMPLEIO PRODUCTS AND MATERIALS AT YOUR OWN RISK.**

The longer version:

QUICKSOURCE, INC ("QUICKSOURCE") CANNOT ATTEST TO OR ENDORSE THE SAFETY OF USING ANY EQUIPMENT, SUPPLIES OR SERVICES, INCLUDING BUT NOT LIMITED TO THE BARE BOARDS AND KITS ASSEMBLED BY THE PURCHASER, OR COMPLETED BOARDS FROM QUICKSOURCE. THESE PRODUCTS ARE INHERENTLY PART OF A LARGER SYSTEM, AND RELY ON THE SKILL OF THE PURCHASER TO BUILD, INSTALL, AND HANDLE PROPERLY. CIRCUIT BOARDS AND SUPPLIES, SUCH AS, BUT NOT LIMITED TO, TRIACS, CAPACITORS, COILS AND POWER SUPPLIES, ARE INHERENTLY UNSAFE AND CAN INJURE, MAIM OR KILL EVEN WHEN USED APPROPRIATELY. ANY ELECTRICAL CONTROL SITUATION IS INHERENTLY DANGEROUS AND COULD RESULT IN YOUR OR ANY OTHER PERSON'S INJURY, MAIMING OR DEATH.

QUICKSOURCE' SIMPLEIO PRODUCTS ARE NOT DESIGNED WITH COMPONENTS AND TESTING FOR A LEVEL OF RELIABILITY SUITABLE FOR USE IN OR IN CONNECTION WITH CRITICAL COMPONENTS IN ANY LIFE SUPPORT SYSTEMS WHOSE FAILURE TO PERFORM CAN REASONABLY BE EXPECTED TO CAUSE SIGNIFICANT INJURY TO A PERSON OR ANY LIVING CREATURE.

IN ANY APPLICATION, INCLUDING THE ABOVE, RELIABILITY OF OPERATION OF THE PRODUCTS CAN BE IMPAIRED BY ADVERSE FACTORS, INCLUDING, BUT NOT LIMITED TO FLUCTUATIONS IN ELECTRICAL POWER SUPPLY, COMPUTER HARDWARE MALFUNCTIONS, COMPUTER OPERATING SYSTEM SOFTWARE FITNESS, INSTALLATION ERRORS, SOFTWARE AND HARDWARE COMPATIBILITY PROBLEMS, MALFUNCTIONS OR FAILURES OF ELECTRONIC MONITORING OR CONTROL DEVICES, TRANSIENT FAILURES OF ELECTRONIC SYSTEMS (HARDWARE AND/OR SOFTWARE), UNANTICIPATED USES OR MISUSES, OR ERRORS ON THE PART OF THE USER OR APPLICATIONS DESIGNER (ADVERSE FACTORS SUCH AS THESE ARE HEREAFTER COLLECTIVELY TERMED "SYSTEM FAILURES"), ANY APPLICATION WHERE A SYSTEM FAILURE WOULD CREATE A RISK OF HARM TO PROPERTY OR PERSONS (INCLUDING THE RISK OF BODILY INJURY AND DEATH) SHOULD NOT BE RELIANT SOLELY UPON ONE FORM OF ELECTRONIC SYSTEM DUE TO THE RISK OF SYSTEM FAILURE. TO AVOID DAMAGE, INJURY, OR DEATH, THE USER OR INSTALLER MUST TAKE REASONABLY PRUDENT STEPS TO PROTECT AGAINST SYSTEM FAILURES, INCLUDING BUT NOT LIMITED TO BACK-UP OR SHUT DOWN MECHANISMS. BECAUSE EACH END-USER SYSTEM IS CUSTOMIZED, AND BECAUSE A USER OR INSTALLER MAY USE QUICKSOURCE PRODUCTS IN COMBINATION WITH OTHER PRODUCTS IN A MANNER NOT EVALUATED OR CONTEMPLATED BY QUICKSOURCE, THE USER OR INSTALLER IS ULTIMATELY RESPONSIBLE FOR VERIFYING AND VALIDATING THE SUITABILITY OF QUICKSOURCE PRODUCTS WHENEVER QUICKSOURCE PRODUCTS ARE INCORPORATED IN A SYSTEM OR APPLICATION, INCLUDING, WITHOUT LIMITATION, THE APPROPRIATE DESIGN, PROCESS, AND SAFETY LEVEL OF SUCH SYSTEM OR APPLICATION.

Copyright 2004 - 2005 QuickSource, Inc.

Unless otherwise specified, all materials containing logos, graphics, icons and images of QuickSource and SimpleIO, as well as the selection, assembly, and arrangement, are the sole property of QuickSource, Inc.

No materials may be copied, reproduced, modified, republished, uploaded, posted, transmitted, or distributed in any form or by any means without prior written permission.

All rights are reserved.
